

(12) **UK Patent Application** (19) **GB** (11) **2 260 209** (13) **A**

(43) Date of A publication 07.04.1993

(21) Application No 9120904.9

(22) Date of filing 02.10.1991

(71) Applicant  
**Brian Roger Hardy**  
 Storage Lodge, Redmires Road, Redmires, Sheffield,  
 S10 4QZ, United Kingdom

(72) Inventor  
**Brian Roger Hardy**

(74) Agent and/or Address for Service  
 Wilson, Gunn and Ellis  
 Premier House, 14 Cross Burgess Street, Sheffield,  
 S1 2HG, United Kingdom

(51) INT. CL.  
 G08G 1/16

(52) UK CL (Edition L)  
 G40 QCE  
 U1S S1820 S1990 S2013 S2145 S2184

(56) Documents cited  
 GB 2254509 A GB 2222710 A GB 2007841 A  
 WO 87/02812 A1

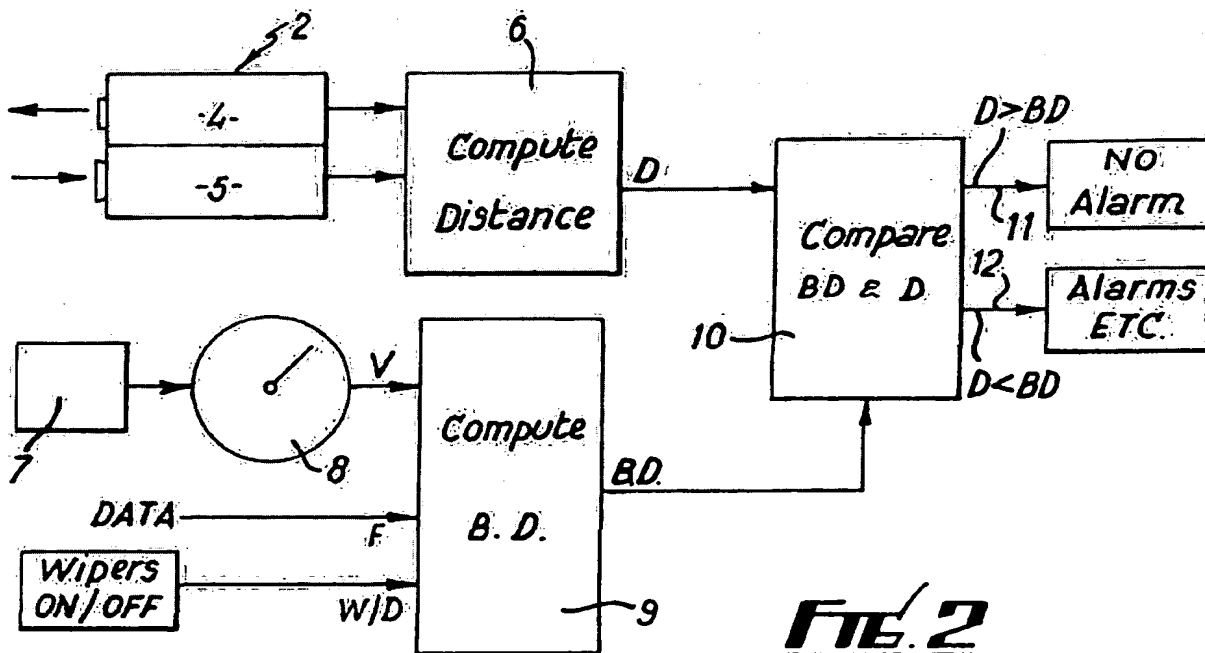
(58) Field of search  
 UK CL (Edition K) G40 QCC QCE QCF, H40 DLRA  
 DLRC DLRE DLRG DRPC DSPK  
 INT. CL. G08G

Best Available Copy

(54) **Braking distance indicating and warning device**

(57) A device mounted in an automobile vehicle includes a signal emitting device 4, and a detector 5 for detecting a reflected signal from a preceding vehicle. A device 6 computes the distance of the preceding vehicle which is compared 10 with braking distance BD computed 9 with reference to own vehicle speed V, road state W/D, and other data F.

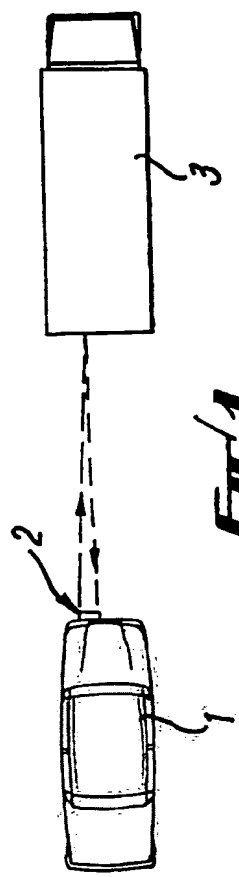
If BD is greater than D, then an alarm signal 12 is generated. Alarms may be visual displays and/or audible signals or messages. A continuous display may be provided in analog or digital form. A warning message may be displayed to a following vehicle.



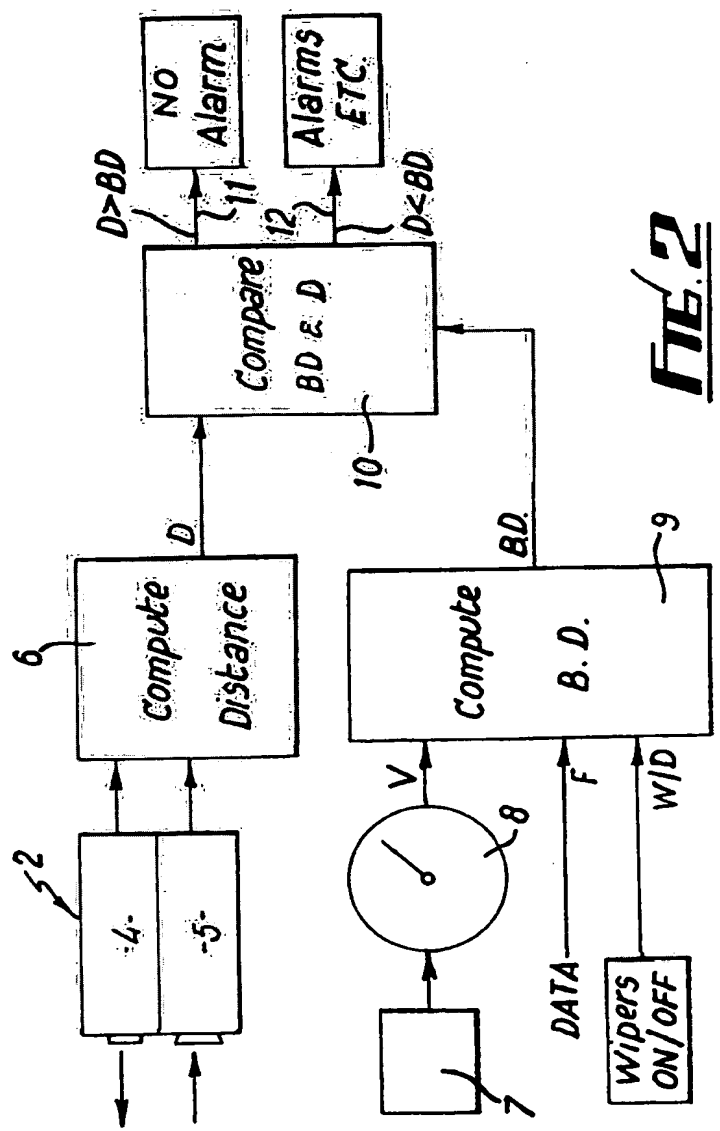
**FIG. 2**

At least one drawing originally filed was informal and the print reproduced here is taken from a later filed formal copy  
 The claims were filed later than the filing date within the period prescribed by Rule 25(1) of the Patents Rules 1990  
 At least one of these pages has been prepared from an original which was unsuitable for direct photoreproduction

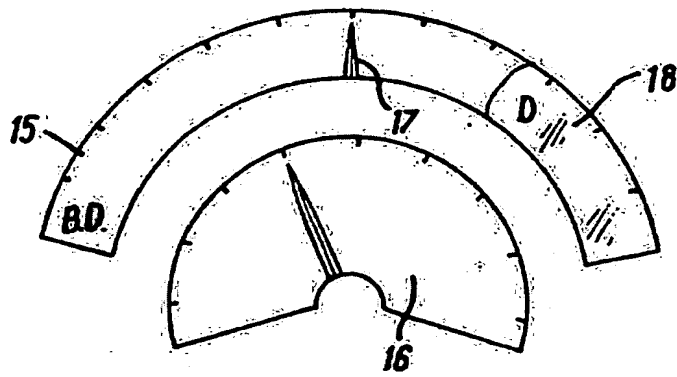
JUL 20 1993



**FIG. 1**

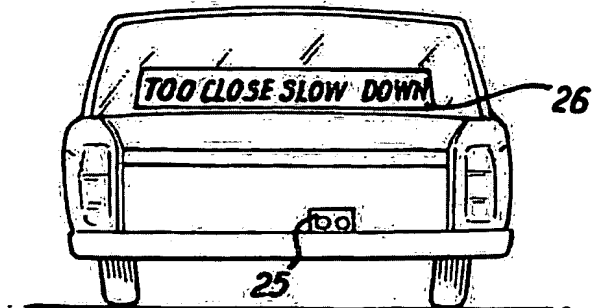
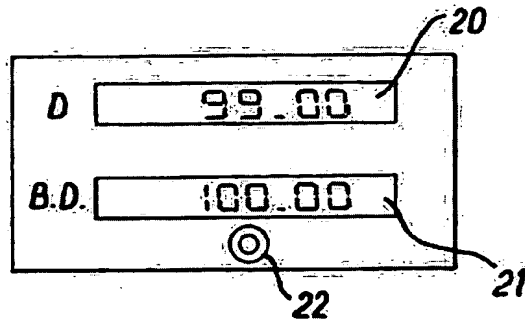


**FIG. 2**



**FIG. 3**

**FIG. 4**



**FIG. 5**

Braking Distance Indicating and Warning Device

This invention relates to a braking distance indicating and warning device.

It is generally acknowledged that motorists, driving at high speeds for example on motorways frequently drive their own vehicle too close to an immediately preceding vehicle to be able to avoid collision should the vehicle in front stop, or indeed merely check its speed. The distance in which a vehicle can be brought to a halt at any given speed is known as the 'braking distance' and varies not only with speed; but also the weight of the vehicle including its probably variable load from one journey to the next, load; the condition of its brakes; and the road surface, particularly whether wet or dry. The consequences of driving too close are all too well known, and often involve multi-vehicle end-to end collisions occurring as a result of a leading vehicle experiencing catastrophic failure of some kind such as a tire blow-out, or colliding with another vehicle or a road fixture in poor visibility. Nevertheless, despite repeated warnings by police and road organisations, too-close following of a preceding vehicle is virtually universal.

An object of the present invention is to provide an indicating and warning device which will give an indication to a driver that his vehicle is too close to an immediately preceding vehicle, that is that the separation of his vehicle from the vehicle in front is less than the safe braking distance of his vehicle at the speed at which his vehicle is moving at the instant of measurement.

According to the invention, an indicating and warning device comprises means for detecting the distance between two vehicles, in one of which the dive is located; means for determining the velocity of the said one vehicle; means for computing a safe braking distance for the vehicle in relation to at least the velocity thereof; means for comparing the computed distance with the actual distance detected by the detecting means, and means for activating a display or warning if the actual distance is equal to or less than the computed distance.

The distance detecting means may comprise an emitter for emitting a pencil beam of electromagnetic radiation, or pulsed sonic signals at an inaudible ultrasonic frequency for example; a detector for sensing reflection of the emitted sonic or electromagnetic signals; and a circuit for determining the range of a target, e.g. with reference to the time lapse between pulse emission and reception of the reflected pulse. Means for detection of doppler shifting of the reflected signal may also be included, so that an indication can be given of relative velocities, as when the vehicle is overhauling a preceding vehicle.

The velocity of the vehicle may be determined by the usual speedometer of the vehicle, and a signal generated corresponding to the velocity derived from the speedometer and applied to the comparator means.

The computing means and comparator means may be embodied in a microprocessor which is appropriately programmed to compute the braking distance not only from the current speed

of the vehicle, but also with reference to non-variable and other variable data, such as the mass of the vehicle and load, and/or the state of the road, for example alternate values being adopted depending upon whether the road surface is wet or dry, which may in turn be determined simply by whether the windscreen wipers are on or off, as the presence or absence of spray is a good indicator. The micro processor may be programmed to for example sample the speed and distance at e.g. one second intervals, and perform a calculation and comparison for each sample, displaying an appropriate output from the conclusion of one calculation and comparison until the completion of the next.

The micro processor is preferably arranged to drive a display, which may take one or more possible forms. For example one form of visual display may comprise an arcuate window, disposed concentrically about and above a speedometer, graduated to show computed braking distance, and a brightly coloured, eg red, orange, or pink luminescent flag which shows target distance on the same scale. Other forms of display, which may be separately or concurrently used are visual indicators which may e.g. flash and display a legend such as 'TOO CLOSE - SLOW DOWN', audible warnings, and a read out screen displaying simply the braking distance and vehicle distance as a numerical display, with a light which can flash when the vehicle distance is within the braking distance.

Audible warnings may take the form of a beeper or other continuous or discontinuous signal, or a synthesised or recorded

voice speaking a warning message. As a final stage, the processor may be programmed to apply a throttle control or engine governor, or in extremis, apply the brakes of the vehicle.

It is preferred that the warnings should begin with low intensity indications when the braking distance begins to exceed vehicle distance, intensifying as the separation narrows, and becoming strident before any action is taken to intervene in the control of the vehicle.

In another embodiment, an additional device may be mounted to detect the distance of a following vehicle and arranged to display a message such as 'TOO CLOSE-SLOW DOWN' from the rear of the vehicle so as to be visible to the driver of a following vehicle.

A preferred embodiment of device according to the invention will now be described by way of example, with reference to the accompanying drawings, wherein:-

Fig. 1 is a diagrammatic plan view of a vehicle carrying the device according to the invention, and a preceding vehicle;

Fig. 2 is a block logic diagram illustrating the mode of operation of the device;

Fig. 3 is an elevation view of an embodiment of display forming part of the device according to the invention;

Fig. 4 is a diagram of a continuous digital display; and

Fig. 5 is a rear view of a vehicle fitted with a modified form of the device.

As shown in Fig. 1, a car 1 is equipped with a braking distance indicating and warning device according to the invention.

This includes a transmitter and detector mounted in a housing 2 on the front of the vehicle for emitting a signal and detecting the reflection of the signal from a preceding vehicle, such as truck 3. The emitted and reflected signal may for example be a suitably modulated electromagnetic signal (e.g. infra-red) or a sonic signal.

The transmitter 4 and detector 5 are in Fig. 2 connected to a computing device 6 which computes the distance D between the vehicles 1 and 3 by reference to some characteristic of the reflected signal as compared to the transmitted signal; e.g. continuous doppler measurements in conjunction with the velocity of the home vehicle 1 may allow distance at any time to be computed, or with sonic signals, the time lag between transmitted and reflected signals may allow distance to be computed on the principle of 'Sonar'. Geometric methods, e.g. triangulation of the direction of reflected signals may be used if the transmitter and detector are set apart on a base line of say 1 metre; *(another method may be based on the strength of the reflected signal, using the 'inverse square' law.)*

In addition, inputs are taken from an own-vehicle speed sensor 7 with the usual speedometer display 8 to produce a speed input V, and a data input F of the required braking distance formula; and a further input W/D which indicates whether the road surface is wet or dry, taken from the on/off state of the wind screen wipers. The inputs V, F, and W/D are applied to a computing device 9 which produces a value BD, braking distance, which indicates the safe braking distance of the vehicle at the current speed on present road conditions.



The output BD from device 9, and D from device 6 are input to a comparator 10 which simply determines whether D or BD is the greater and actuates alternative outputs 11, 12 accordingly.

Output 11 is actuated while  $D > BD$ , that is the own vehicle 1 can be brought safely to a halt without colliding with the rear of the preceding vehicle 3. While output 11 is live, there is no alarm condition, and warning lights are not displayed, nor other measures taken.

When  $D < BD$ , output 12 is actuated, as the own vehicle 1 can no longer be brought safely to a halt. Flashing lights and other alarm indicators may be activated in the alarm condition thus initiated, and an increasing excess of BD over D may when set thresholds have been passed, actuate a graduated series of alarms for example the first indication may be a flashing light, followed by a taped or synthetic voice announcement, leading to more extreme visual and auditory warnings before proceeding to gradually close the throttle so that the vehicle loses engine power and thus cannot maintain speed, and thus falls further behind the preceding vehicle.

In addition, the outputs BD and D of devices 6 and 9 may be used to drive continuous displays such as is shown in Fig. 3 wherein an additional arcuate display window 15 is disposed concentrically above a standard speedometer dial 16, and is graduated to display braking distance in metres. A pointer 17 indicates the moment-to-moment braking distance, whilst the distance to the nearest preceding vehicle is indicated by a brightly coloured flag 18.

Alternatively, a numerical display may be used, as in Fig. 4, wherein one display 20 for distance is juxtaposed above a second display 21 for braking distance, A light 22 may be associated with the numerical displays, and begin flashing when braking distance begins to exceed the range to the preceding vehicle, e.g. as shown wherein the excess is marginal.

Finally, in an alternative or additional embodiment, a similar arrangement of transmitter and detector 25 may be mounted on the rear of a car, with the same computing arrangements as suggested above. However the main display is a warning sign 26 carried for example on the rear shelf of the car, with an appropriate legend such as ' TOO CLOSE-SLOW DOWN' which is actuated when a following vehicle is computed as being within braking distance of the rear of the vehicle.

It will be appreciated that the computational functions of the devices 6, 9, and 10 may be embodied in a suitably programmed microprocessor. The program of the latter may if desired may take into account all manner of complex interacting factors; or deal with a simplified formula with a written in safety factor.

In an additional device, an arrangement may be provided whereby braking lights of a vehicle are illuminated with variable intensity as the brake pressure increases or decreases. For example, when a light brake pressure is used only two lamps may be lit, while with a medium pressure four, and in braking hard six lamps may be lit. This will indicate to a following vehicle whether the vehicle will slow down suddenly, or more gradually.

Claims

1. A braking distance indicating and warning device comprising detecting means for detecting the distance between two vehicles, in one of which the device is located:
  - means for determining the velocity of said one vehicle;
  - means for computing a safe braking distance for the vehicle in relation to at least the velocity thereof;
  - means for comparing the computed distance with the actual distance detected by said detecting means; and
  - means for activating a display or warning if the actual distance is equal to or less than the computed distance.
  
2. A device according to claim 1 wherein said detecting means comprises an emitter for emitting a pencil beam of electromagnetic radiation, a detector for sensing reflection of the emitted electromagnetic signals; and a circuit for determining the range of said second vehicle.
  
3. A device according to claim 1 wherein said detecting means comprises an emitter for emitting pulsed sonic signals at an inaudible ultrasonic frequency, a detector for sensing reflected sonic signals, and a circuit for determining the range of said second vehicle.

4. A device according to claim 2 or 3 wherein the range determining circuit is operative to determine the range of the second vehicle by reference to the time lapse between emission of a pulse and reception of the reflection of the pulse.

5. A device according to claim 4 including means for detecting doppler shifting of the reflected signal; so that an indication may be given of relative velocity of said vehicles.

6. A device according to claim 5 wherein the means for determining the velocity of the vehicle is constituted by the speedometer of the vehicle, and means for generating a signal corresponding to the velocity derived from the speedometer for application to the computing means.

7. A device according to any preceding claim wherein the computing means and comparator means are embodied in a microprocessor which is appropriately programmed to compute the braking distance, with reference to the velocity of the vehicle, and to data concerning the mass of the vehicle, and the rate of the road.

8. A device according to claim 7 wherein the microprocessor is programmed to sample the speed and distance at frequent intervals and perform a calculation and comparison for each

sample.

9. A device according to claim 7 or 8 wherein the microprocessor has outputs connected to drive a visual display.

10. A device according to claim 9 wherein said visual display comprises an arcuate window disposed concentrically about and above a speedometer dial, the window being graduated to show computed braking distance, and a brightly coloured flag which shows the distance of the other vehicle on the same scale.

11. A device according to claim 9 wherein said visual display includes an indicator which can flash and display a legend such as 'TOO CLOSE - SLOW DOWN'.

12. A device according to claim 7 or 8 wherein said microprocessor has outputs connected to drive an audible warning device.

13. A device according to claim 12 wherein the audible warning device is any one or more of beeper; a continuous or a discontinuous sonic signal; or a synthesised or recorded voice speaking a warning message.

14. A device according to claim 7 or 8 wherein said

microprocessor is programmed to apply or throttle control or engine governor, and/or apply the brakes of the vehicle.

15. A braking distance indicating and warning device substantially as hereinbefore described, with reference to and as illustrated in the accompanying drawings.

**Patents Act 1977**  
**Examiner's report to the Comptroller under**  
**Section 17 (The Search Report)**

Application number

GB 9120904.9

**Relevant Technical fields**

- (i) UK CI (Edition K ) G4Q (QCE, QCC, QCF)  
 H4D (DRPC, DSPK, DLRA, DLRC, DLRE,  
 DLRG)  
 (ii) Int CI (Edition 5 ) G08G

**Search Examiner**

M J DAVIS

**Databases (see over)**

(i) UK Patent Office

(ii)

**Date of Search**

3.11.92

Documents considered relevant following a search in respect of claims 1-15

Category (see over)	Identity of document and relevant passages	Relevant to claim(s)
X, E	GB 2254509 A (CLARK) whole document	1 at least
X	GB 2222710 A (HOME) whole document	1-15
X	GB 2007841 A (NISSAN) whole document	1-15
X	WO 87/02812 A1 (ATTIKIOUZEL ET AL) whole document	1-15

Category	Identity of document and relevant passages	Relevant to claim(s).

**Categories of documents**

**X:** Document indicating lack of novelty or of inventive step.

**Y:** Document indicating lack of inventive step if combined with one or more other documents of the same category.

**A:** Document indicating technological background and/or state of the art.

**P:** Document published on or after the declared priority date but before the filing date of the present application.

**E:** Patent document published on or after, but with priority date earlier than, the filing date of the present application.

**&:** Member of the same patent family, corresponding document.

**Databases:** The UK Patent Office database comprises classified collections of GB, EP, WO and US patent specifications as outlined periodically in the Official Journal (Patents). The on-line databases considered for search are also listed periodically in the Official Journal (Patents).



**This Page is Inserted by IFW Indexing and Scanning  
Operations and is not part of the Official Record**

**BEST AVAILABLE IMAGES**

Defective images within this document are accurate representations of the original documents submitted by the applicant.

Defects in the images include but are not limited to the items checked:

- BLACK BORDERS**
- IMAGE CUT OFF AT TOP, BOTTOM OR SIDES**
- FADED TEXT OR DRAWING**
- BLURRED OR ILLEGIBLE TEXT OR DRAWING**
- SKEWED/SLANTED IMAGES**
- COLOR OR BLACK AND WHITE PHOTOGRAPHS**
- GRAY SCALE DOCUMENTS**
- LINES OR MARKS ON ORIGINAL DOCUMENT**
- REFERENCE(S) OR EXHIBIT(S) SUBMITTED ARE POOR QUALITY**
- OTHER:** \_\_\_\_\_

**IMAGES ARE BEST AVAILABLE COPY.**

**As rescanning these documents will not correct the image problems checked, please do not report these problems to the IFW Image Problem Mailbox.**

**This Page Blank (uspto)**